

# PHILIPS

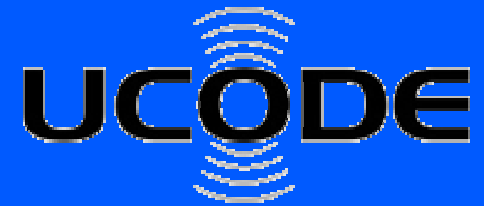

## UCODE EPC Gen 2 Objective Product Information

Hermine Arnold  
Product Manager Smart Label ICs  
Market Sector RFID

2006-01-03

# Key features general

- Suitable for UHF RFID, allowing one IC to be used worldwide
- Interface fully compatible with UHF EPC G2 standard
- Long-range solutions (up to 7 m in the US and 6.6 m in Europe)
- Forward link: 40 - 160 kbits/s
- Return link: 40 - 640 kbits/s
- Multi-label operation at 600 tags/s in Europe, 1600 tags/s in the US
- Runs on the same hardware infrastructure as the UCODE HSL and the UCODE EPC 1.19

# Key features memory

- 512 bit of on-chip memory
- 96 bit EPC
- 64 bit tag Identifier
- 224 bit programmable user memory
- 32 bit access password to allow a transition into the secured transmission state
- 32 bit kill password to permanently disable the tag
- Inventoried flags and selected flag support the handling of persistence information
- Data retention time: 10 Years @  $T_{amb} \leq 55^{\circ}\text{C}$

# General construct of contract for product

- Delivery Types
  - Wafers: 150 $\mu$ m, sawn, 30  $\mu$ m bumped, IBIS mapped on UV tape
  - ICONNECT
  - TSSOP8
- Yield
  - PHILIPS delivers 100% tested die
  - Price: only good die (PHILIPS covers die yield loss)
- Indemnification (against Intermec & others)
  - YES for PHILIPS products (IC, ICONNECT)

# Physical Characteristics

- Wafer characteristics
  - Please refer to the Wafer Addendum Presentation
- Die floor plan
  - Please refer to Wafer Addendum Presentation
- Passivation type (for adhesive compatibility)
  - Please refer to Wafer Addendum Presentation
- Operating temperature min,max
  - - 25 to +85 °C
- Storage temperature (memory retained) min,max
  - - 55 to +125 °C

# Electrical & RF Characteristics

- Operational frequency range
  - 860 MHz to 960 MHz
- Chip impedance
  - $Z = 34.5 - j 815 @ 915\text{MHz}$
  - $Z = 41 - j 865 @ 867\text{ MHz}$
- ESD voltage
  - +/-1 KV

## Gen2 Conformance - general

- Conformance to EPC™ Radio-Frequency Identity Protocols Class-I Generation-2 UHF RFID Protocol for Communications at 860 MHz – 960 MHz, Version 1.0.9
- All mandatory commands fully supported, additional support of optional as well as custom commands

# UCODE EPC G2 Command Set

in accordance with EPC™ Radio-Frequency Identity Protocols Class-I Generation-2 UHF RFID Protocol for Communications at 860 MHz – 960 MHz, Version 1.0.9

<b>Mandatory</b>	<b>Code</b>	<b>Optional</b>	<b>Code</b>
QueryRep	00	Access	11000110
ACK	01	BlockWrite	11000111
Query	1000		
QueryAdjust	1001		
Select	1010	<b>Custom</b>	<b>Code</b>
NAK	11000000	BlockLock	11100000
Req_RN	11000001		00000000
Read	11000010	ChangeEAS	11100000
Write	11000011		00000011
Kill	11000100	EASAlarm	11100000
Lock	11000101		00000100

# Gen2 Conformance – modulation, encoding

## Forward link:

- Modulation
  - DSB-ASK
  - SSB-ASK
  - PR-ASK
- Data coding
  - PIE

Interrogators shall use a fixed modulation format and data rate for the duration of an inventory round

# Gen2 Conformance – modulation, encoding

## Backward link:

- Modulation
  - ASK
- Data coding
  - FM0 for base band mode
  - Miller M=2,4,8 for sub carrier mode

## Gen2 Conformance – data rates

- Forward PIE (table 6.5):  
40, 80, & 160 kbps
- Return FM0 (table 6.11):  
40, 160, 320, 640 kbps
- Return Miller (number of sub carrier cycles per symbol can be 2, 4 or 8; table 6.12):
  - Data Rate is FM0 link frequency divided by sub carrier cycles per symbol

## Gen2 Conformance – persistence

- Persistence cells (table 6.15):
  - Session 0: NO persistence
  - Session 1: 0.5s to 5s (nominal temp. range)
  - Session 2,3: greater than 2s (nominal temp. range)
  - Select flag: greater than 2s (nominal temp. range)

# PHILIPS

**UCODE EPC G2**

**Memory layout**

# Tag memory

- Logically separated into **four** distinct banks

**User memory** allows user-specific data storage. The memory organization is user-defined.

**Tag Identification memory** contain an 8-bit ISO 15693 allocation class identifier (11100010<sub>b</sub> for EPCglobal) [00<sub>h</sub>-07<sub>h</sub>], a 12-bit Tag mask-designer identifier [08<sub>h</sub>-13<sub>h</sub>], and a 12-bit Tag model number [14<sub>h</sub> to 1F<sub>h</sub>] and a 32 bit serial number [20<sub>h</sub> to 3F<sub>h</sub>].

**EPC memory** contain a CRC-16 [00<sub>h</sub>-0F<sub>h</sub>], Protocol-Control (PC) bits [10<sub>h</sub>-1F<sub>h</sub>], and an EPC code beginning at address [20<sub>h</sub>].

**Reserved memory** contain kill and access passwords.

kill password [00<sub>h</sub>-1F<sub>h</sub>]  
access password [20<sub>h</sub>-3F<sub>h</sub>]

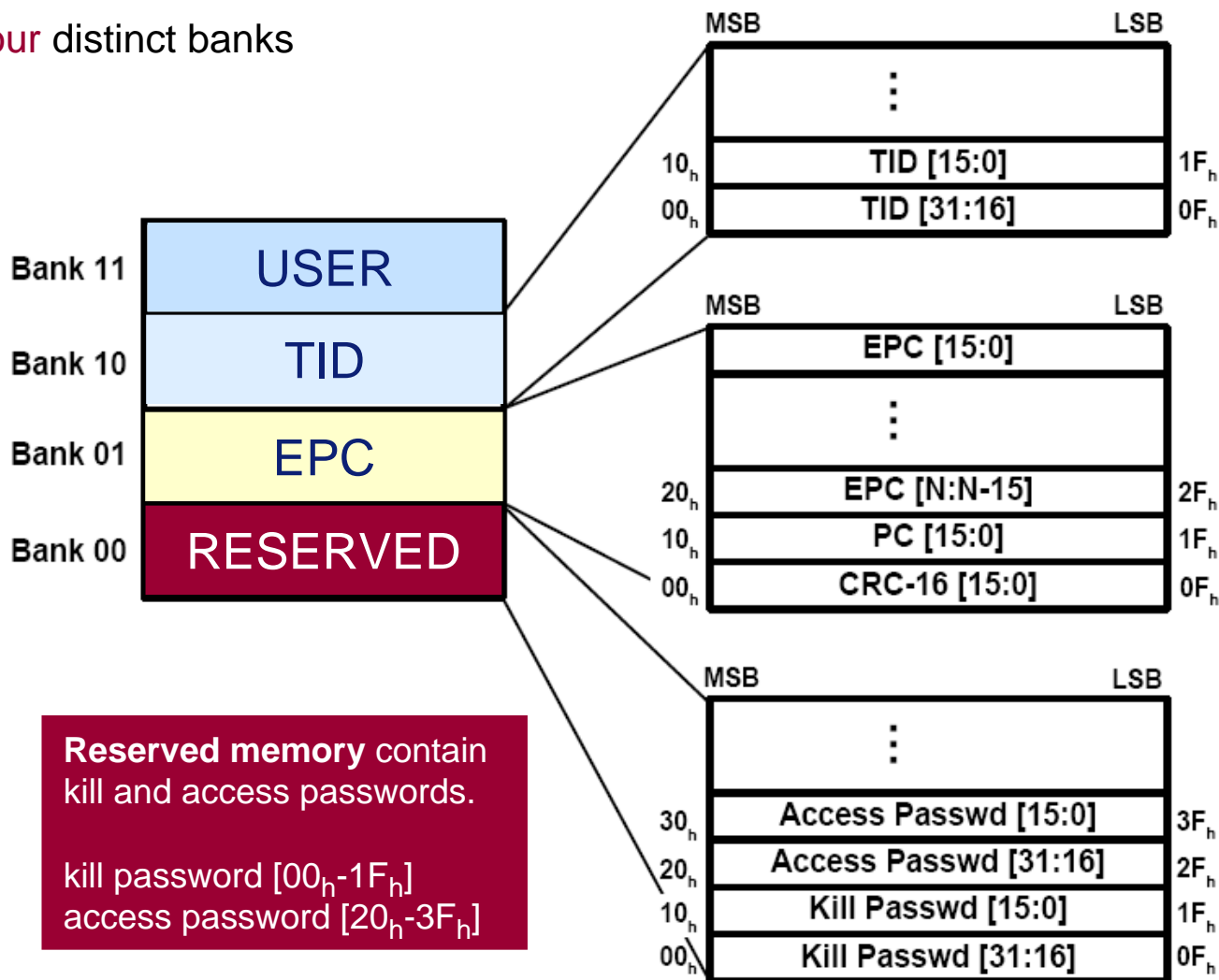

# UCODE EPC G2 Memory

ADDRESS	TYPE	CONTENT	INITIAL <sup>1)</sup>	REMARK
00 <sub>h</sub> – 1F <sub>h</sub>	Reserved	kill password:	all 00 <sub>h</sub>	unlocked memory
20 <sub>h</sub> – 3F <sub>h</sub>	Reserved	access password	all 00 <sub>h</sub>	unlocked memory
00 <sub>h</sub> – 0F <sub>h</sub>	EPC	CRC-16		memory mapped calculated CRC
10 <sub>h</sub> – 14 <sub>h</sub>	EPC	Protocol-control bits	all 00 <sub>h</sub>	unlocked memory
15 <sub>h</sub> – 16 <sub>h</sub>	EPC	RFU	00 <sub>b</sub>	unlocked memory
17 <sub>h</sub> – 1F <sub>h</sub>	EPC	NSI	00 <sub>h</sub>	unlocked memory
20 <sub>h</sub> - 5F <sub>h</sub>	EPC	EPC	undefined <sup>2)</sup>	unlocked memory

# UCODE EPC G2 Memory

ADDRESS	TYPE	CONTENT	INITIAL <sup>1)</sup>	REMARK
00 <sub>h</sub> – 07 <sub>h</sub>	TID	allocation class identifier	1110 0010 <sub>2</sub>	locked memory
08 <sub>h</sub> – 13 <sub>h</sub>	TID	tag mask designer identifier	0000 0000 0110 <sub>2</sub>	locked memory
14 <sub>h</sub> – 1F <sub>h</sub>	TID	tag model number	0000 0000 0001 <sub>2</sub>	locked memory
20 <sub>h</sub> – 3F <sub>h</sub>	TID	serial number	SNR	locked memory
00 <sub>h</sub> – DF <sub>h</sub>	User	user memory	undefined <sup>2)</sup>	unlocked memory

**Notes:**

- 1) This is the initial memory content when delivered by Philips
- 2) Contents of this memory area is not defined during chip product

# PHILIPS

**UCODE EPC G2**  
**Custom Commands**

## BlockLock

- Additional locking mechanism.
- Allows locking of individual 32 bit blocks in the 224 bit user memory.
- Once locked cannot be unlocked.
- If either lock (permalock or individual block) applies for addressed memory, write command will fail.

# ChangeEAS

- Allows the interrogator to set or reset the EAS System Bit.
- ChangeEAS can be executed from secured state.

## EASAlarm

- Causes the UCODE EPC G2 IC to backscatter its ALARM code.
- Prior to EASAlarm ChangeEAS command must have been carried out successfully.
- EAS Code is generated by means of a CRC-5 generator.
- Reply to EASAlarm is protected by a CRC-16.

